

MARELLA

OWNERS MANUAL

FRANKFORD

exceptional shade



Setting up your Stems and Base(s)

PRO-TIP: Designate the installation clearing and estimate the footprint using the measurements.

Then unpack your galvanized plates at those corners.

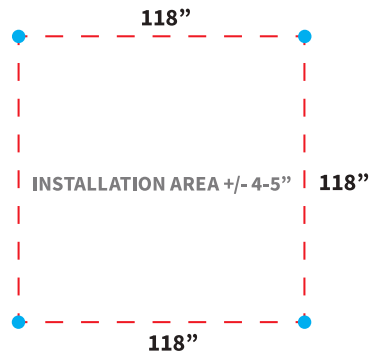

How to stack your galvanized plates

- Remove all grub screws from galvanized steel plates
- Place your beauty plate and holes lined with threaded holes on the galvanized plate
- Place your stem and use the supplied hardware
Single plate and double plate stacks will have different hardware. Be aware of which you are using.
- Once you've set up all four weighted corners, proceed to anchor the uprights into the stems.

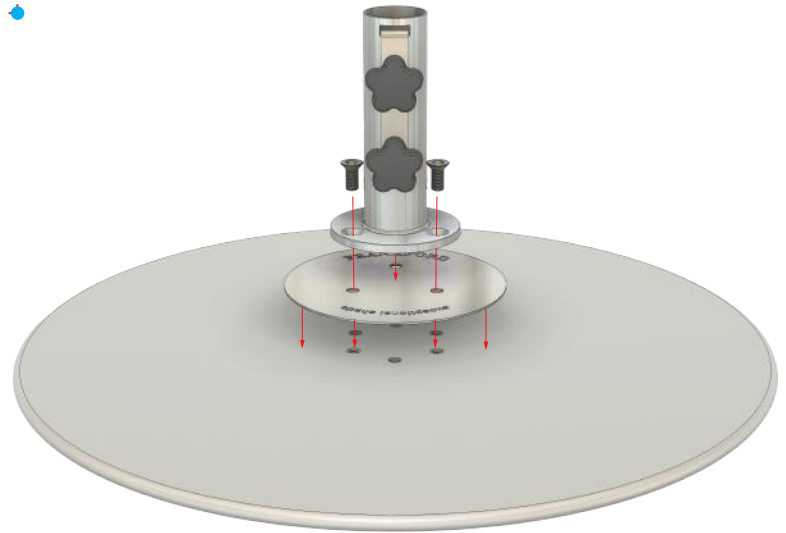

Surface Deck Plate Installation

- Masonry Drill
- 3/8" x 3" Concrete Anchors x16
- Stainless Steel Washers/Shims
- 3/8" wrench (anchor hardware will dictate)

Drill 2.5 - 3" deep (dependin on hardware)

If using Tapcon or other type of screw anchor, use he supplied dill bit with that specific anchor.

Once the deck plate is installed, proceed to attach your stem.

If you're directly mounting your stem to a surface, follow the instructions while omitting the deckplate.

NOTE: Do not install all four corners without completing the Marella. Only install one anchor point corner at either rear corners. This is will you give you a base to build from and adjust.

Once you've completed building the Marella and all uprights are veritcally level, mark your remaining three corners.

Check that the Marella has a level horizon. If-not, shim the corners with staines steel washers until the Marella has a level horizon.

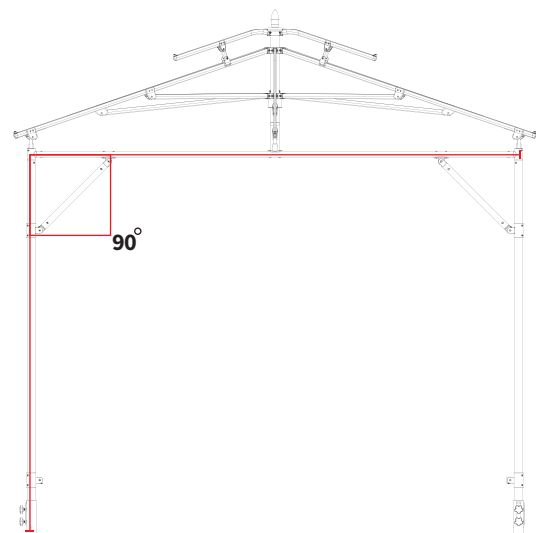
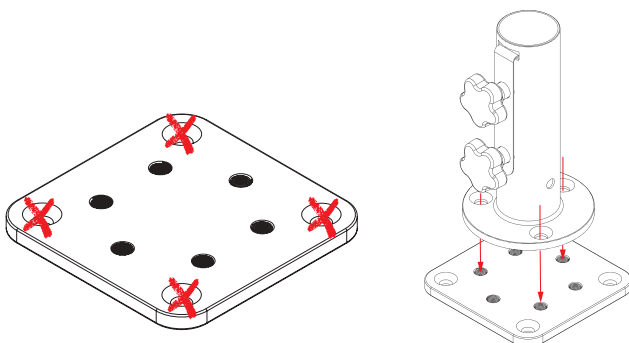

A.1 F.1-2

A.2 F.3-4

C.1

C.2 C.2

C.2 C.2

Barrel Bolts x16

F.5-8

TOOLS NEEDED

- Step Stools (Recommend 3)
- 4mm Hex/Allen
- Rubber Mallet

FRONT x2

REAR x2

B CROSS-MEMBERS x4

C.1

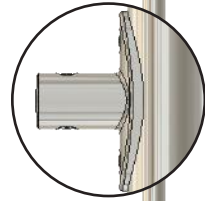
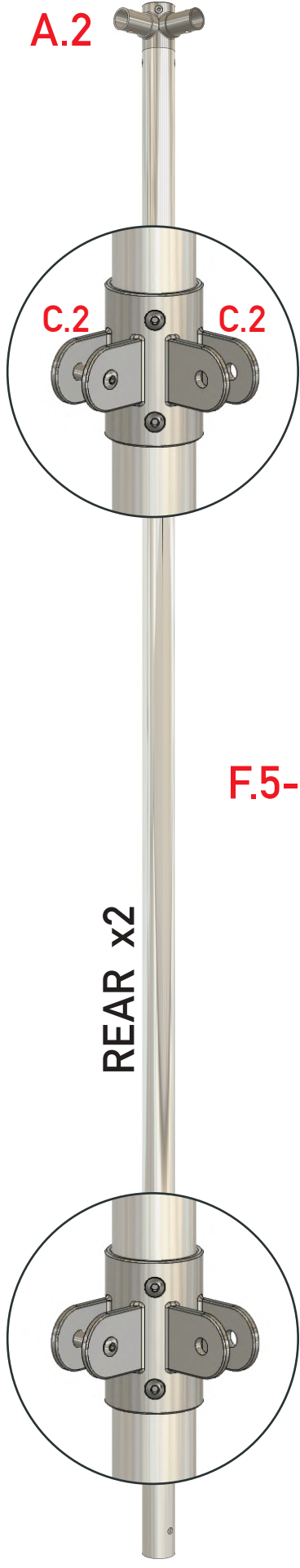
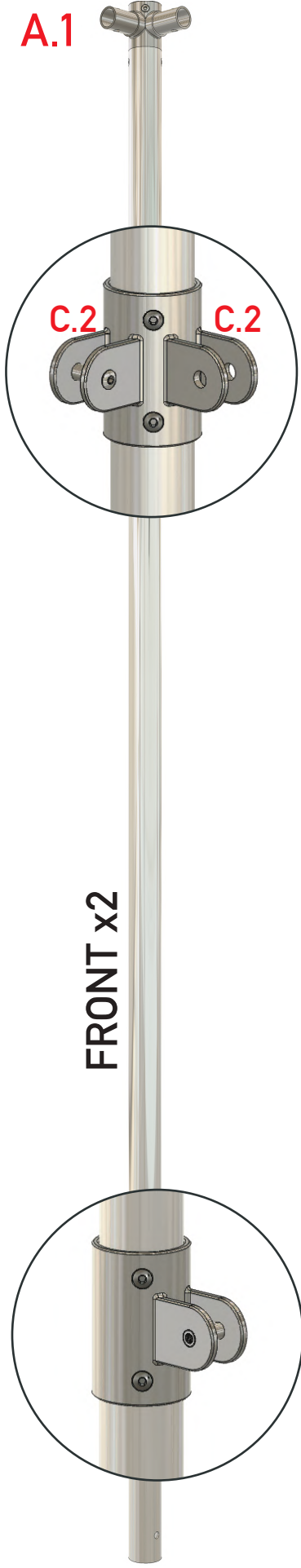

BUILD 1

NOTE: If you're installing Deck Plate mounts or installing directly into the surface, do not install all four corners until completing the Marella.

Only install one anchor point corner at either rear corners (a.2). This will give you a base to build from and adjust.

Once you've completed building the Marella and all uprights are vertically level, mark your remaining three corners.

Check that the Marella has a level horizon. If not, shim the corners with stainless steel washers until the Marella has a level horizon.

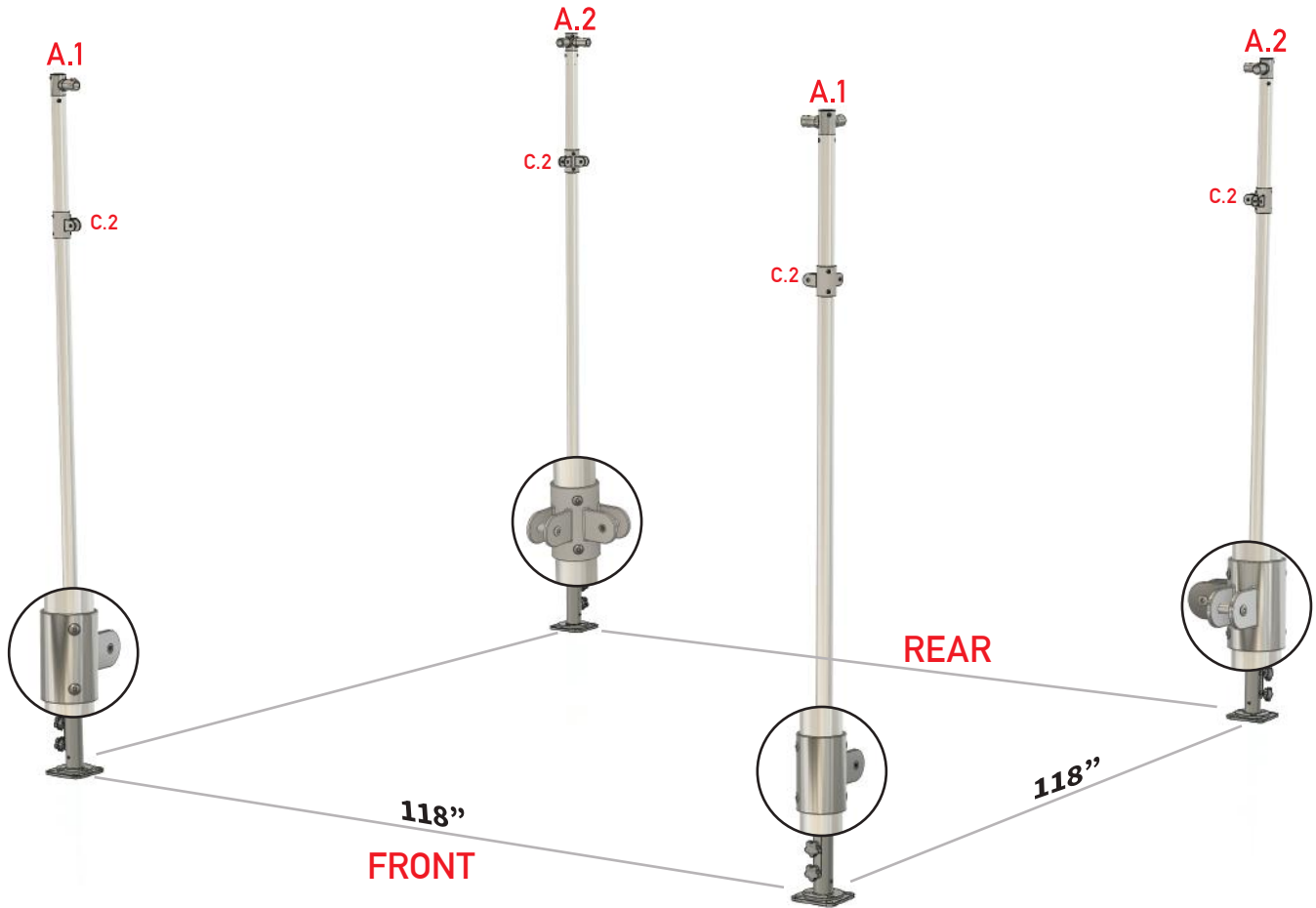

Bases: After you've installed your bases and stems and moved them into position. Insert and anchor all four uprights (a.1), (a.2).

Check that you have spacing roughly 118" x 118". This will be an estimated finished area.

Deck Plate/Surface: You should have one of the rear corners anchored into your concrete surface or deck leaving 3 free floating corners.

This is essential for a single anchoring point and the ability to move and shift the uprights to dock the upper cross-members (b).

If you haven't already, turn to "Attaching Corner Curtains". Then proceed to the next Build Stage.

PRO-TIP: Designate the installation clearing and estimate the footprint using the measurements.

Then unpack your galvanized plates at those corners.

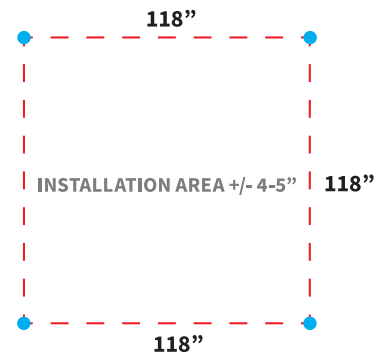

TOOLS NEEDED

- Step Stools (Recommend 3)
- 4mm Hex/Allen
- Rubber Mallet

Attaching Corner Curtains

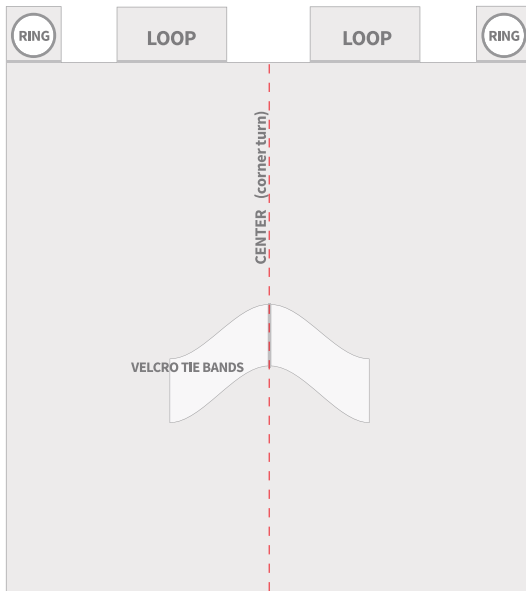

Be sure that the velcro tiebands are on the outside of the curtain before attaching. The 45 support (**c.1**) will be on the inside of the curtain.

You will only install two curtains on the rear cross-member. The side cross-members will only need one curtain installed towards the front of the Marella.

The cross-member (**b**) you've designated as the rear should have two corner curtains installed. The slack of the curtain will be wrapped around the rear uprights and attached to the side cross-members (**b**).

The cross-members (**b**) you've designated as left and right, should have one curtain installed and oriented towards the front entrance of the Marella. The rear curtain slack will install to the naked end of the cross-member (**b**).

Finally, the remaining curtain slack on the sides will install to the front entrance cross-member (**b**) after the canopy frame is installed.

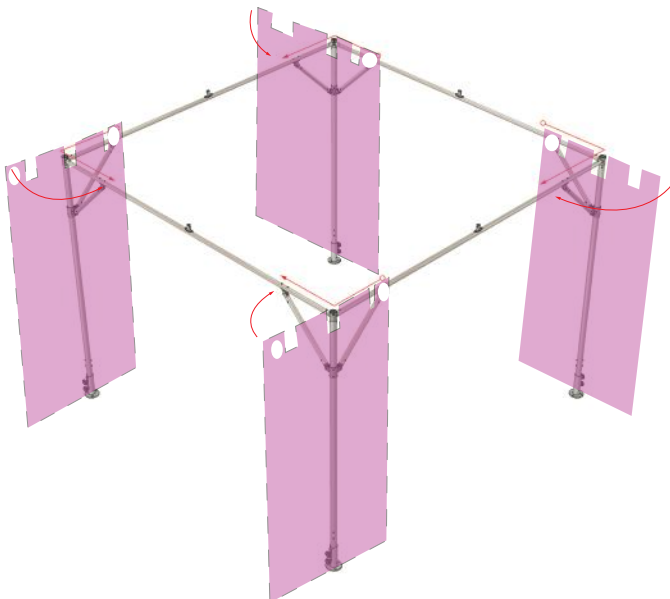

How to:

- Point the 45 Support (**c.1**) outwards to the edge
- Slide the curtain ring onto both the cross-member (**b**) and 45 support (**c.1**).
- When the curtain ring is half the way onto the cross-member (**b**) and 45 support (**c.1**), insert only the cross-member bar into the curtain loop
- When the Ring passes the 45 support lobe, swing the support down and do not let it go through the loop.

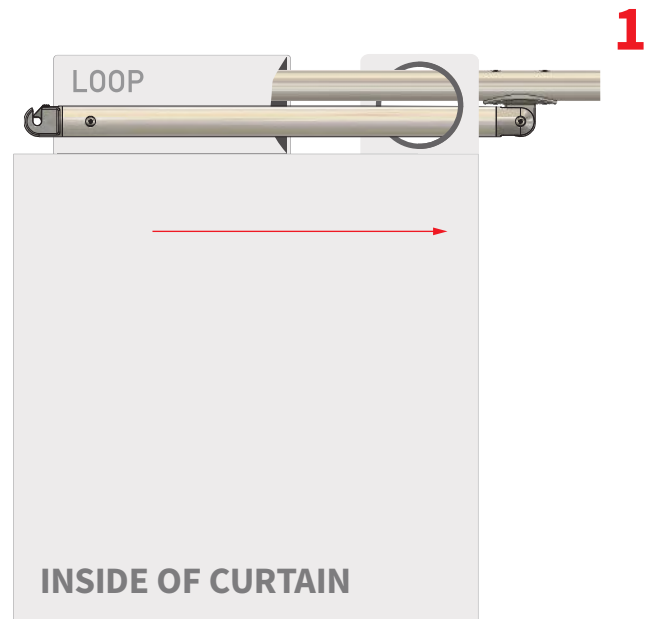

BUILD 2

Rear Cross-Member (b) : This should be the only cross-member that will have two curtains installed before attaching to the Marella uprights.

NOTE: make sure the curtains are oriented properly. Tie-bands will be on the outside.

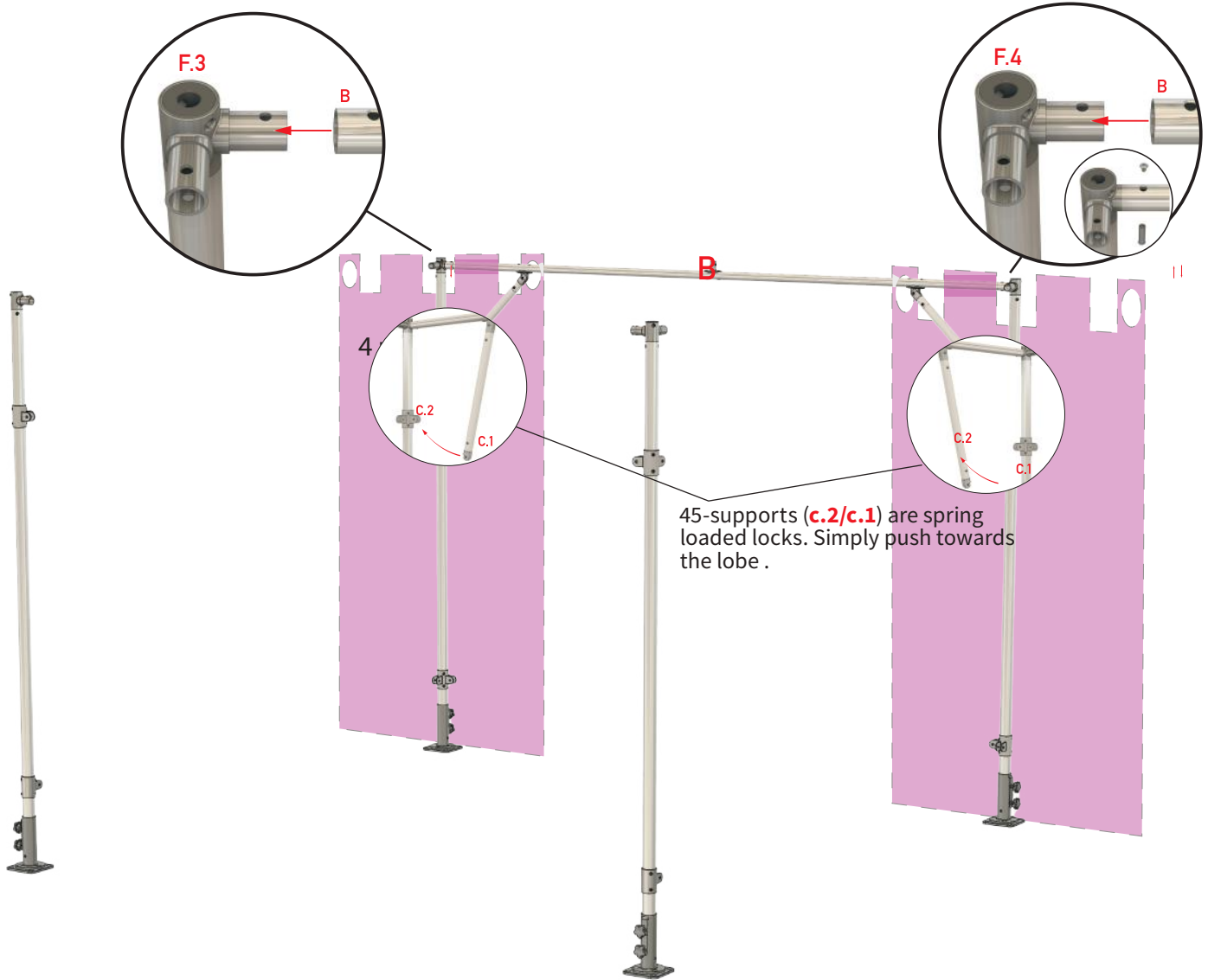

When the cross-member is secured, and the 45-supports (c.2/c.1) are locked in, you should be left with curtain slack on each end.

They will attach to the side cross-members with a curtain attached and oriented towards the front.



TOP VIEW



BUILD 2

Side Cross-Member (b) : Should only have one curtain already installed and will marry to the rear curtains.

NOTE: make sure the curtains are oriented properly. Tie-bands will be on the outside.

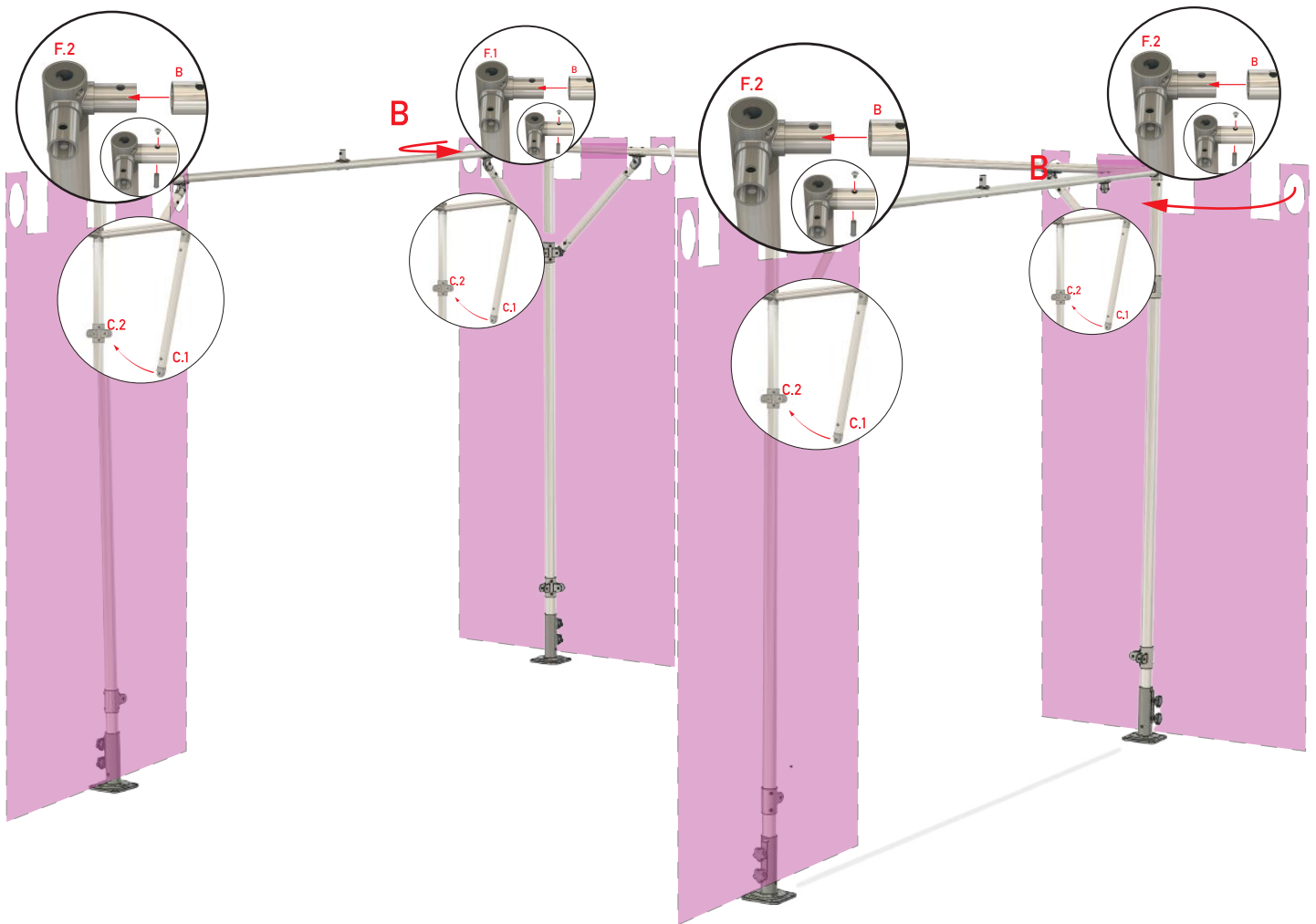

Attach the remaining curtain slack from the rear onto the left and right cross-members.

When the left and right cross-members are secured, you should be left with curtain slack on each end towards the front.

They will attach to the front cross-member, but not until the canopy is inside of the Marella frame and attach to the rear points (f.3/f.7/f.4).

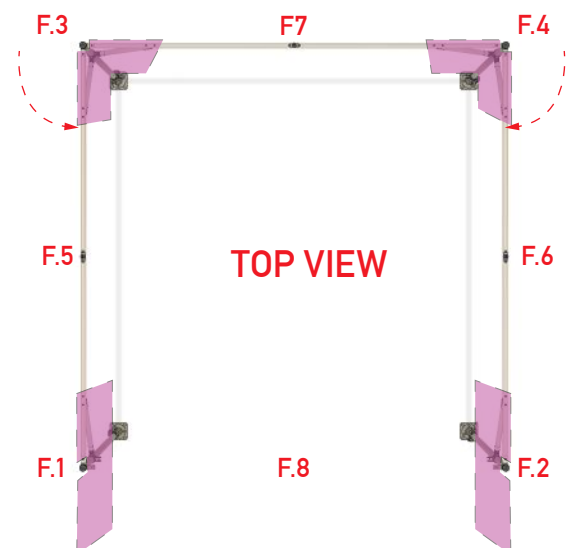

BUILD 3

Canopy Installation Part 1

NOTE: make sure the curtains are oriented properly. Tie-bands will be on the outside.

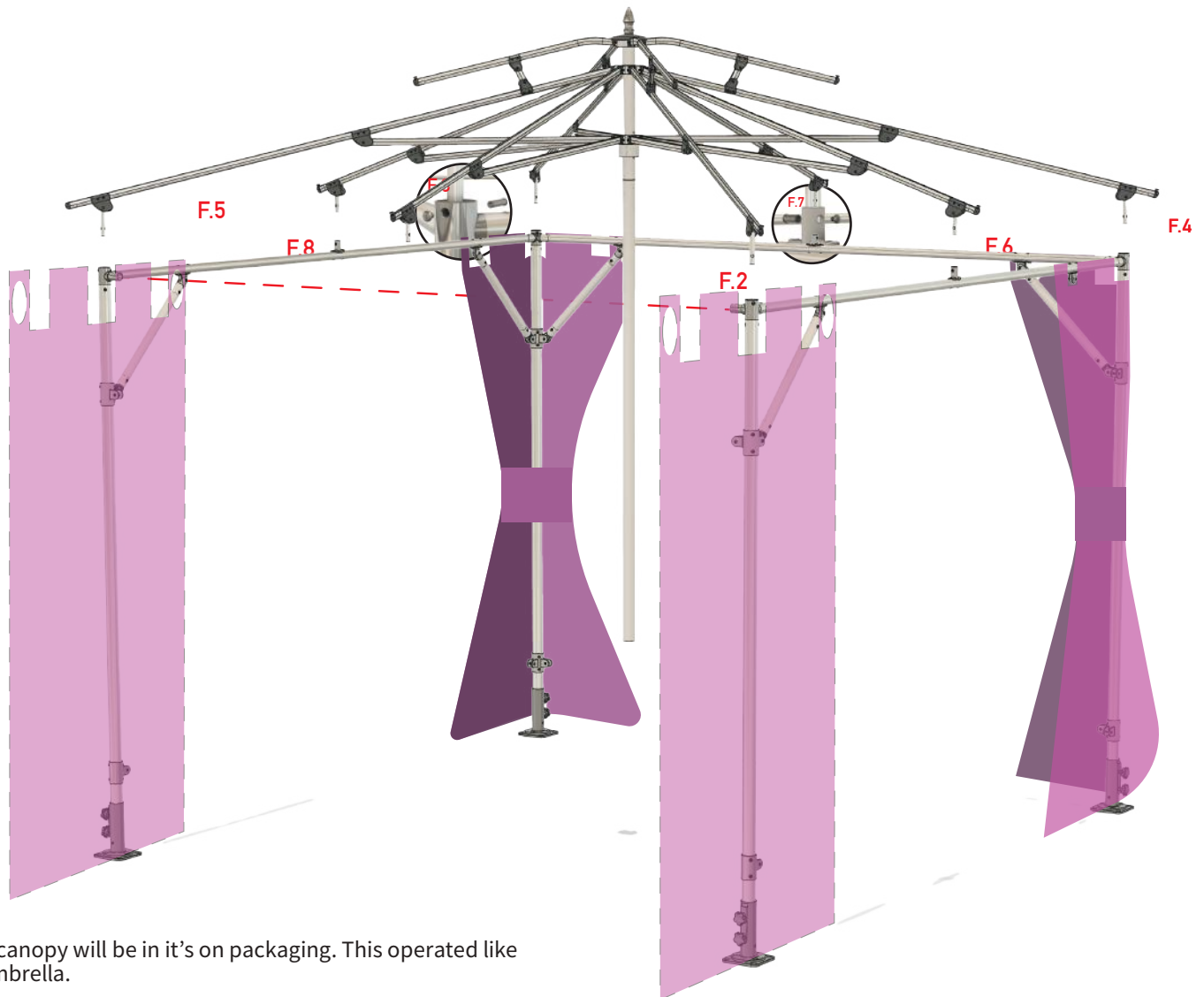

Your canopy will be in it's on packaging. This operated like an umbrella.

- Remove the canopy, locate the center mast and attached the canopy upper center mast portion.
- Install the stainless steel vertex finial
- To open, one person holds the canopy upright, and two others can lift from the rib corners.
- The person holding the canopy upright, then can push the runner into it's auto-lock position and insert the safety pin. The runner should not be resting on the pin.

When the canopy is open, check the docking pins on the end of each rib. Be sure they are facing straight down as much as possible.

Carefull lift the canopy from the center mast and guide it into the Marella open frame and dock the rear points (**f.3/f.7/f.4**).

Do not dock any other point at this time until the front cross-member is installed.

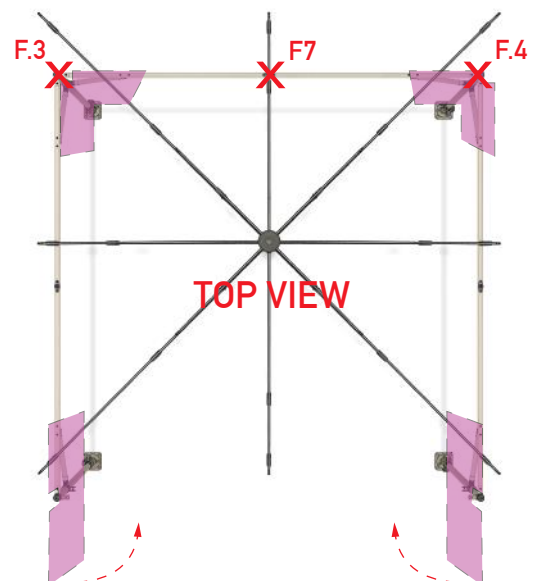

BUILD 4

Canopy Installation Part 2

NOTE: make sure the curtains are oriented properly. Tie-bands will be on the outside.



Attach the remaining curtain slack from the sides onto the remaining front cross-member.

When the cross-member is secured, and the 45-supports (**c.2/c.1**) are locked in, All curtains should be installed.

Proceed to dock the remaining canopy points (**f.1/f.2/f.5/f.6/f.8**)

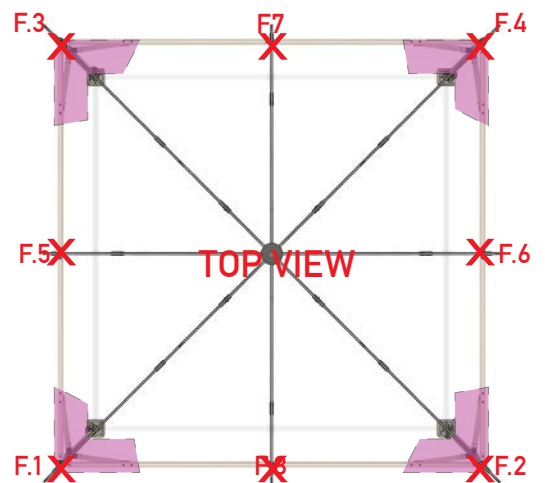

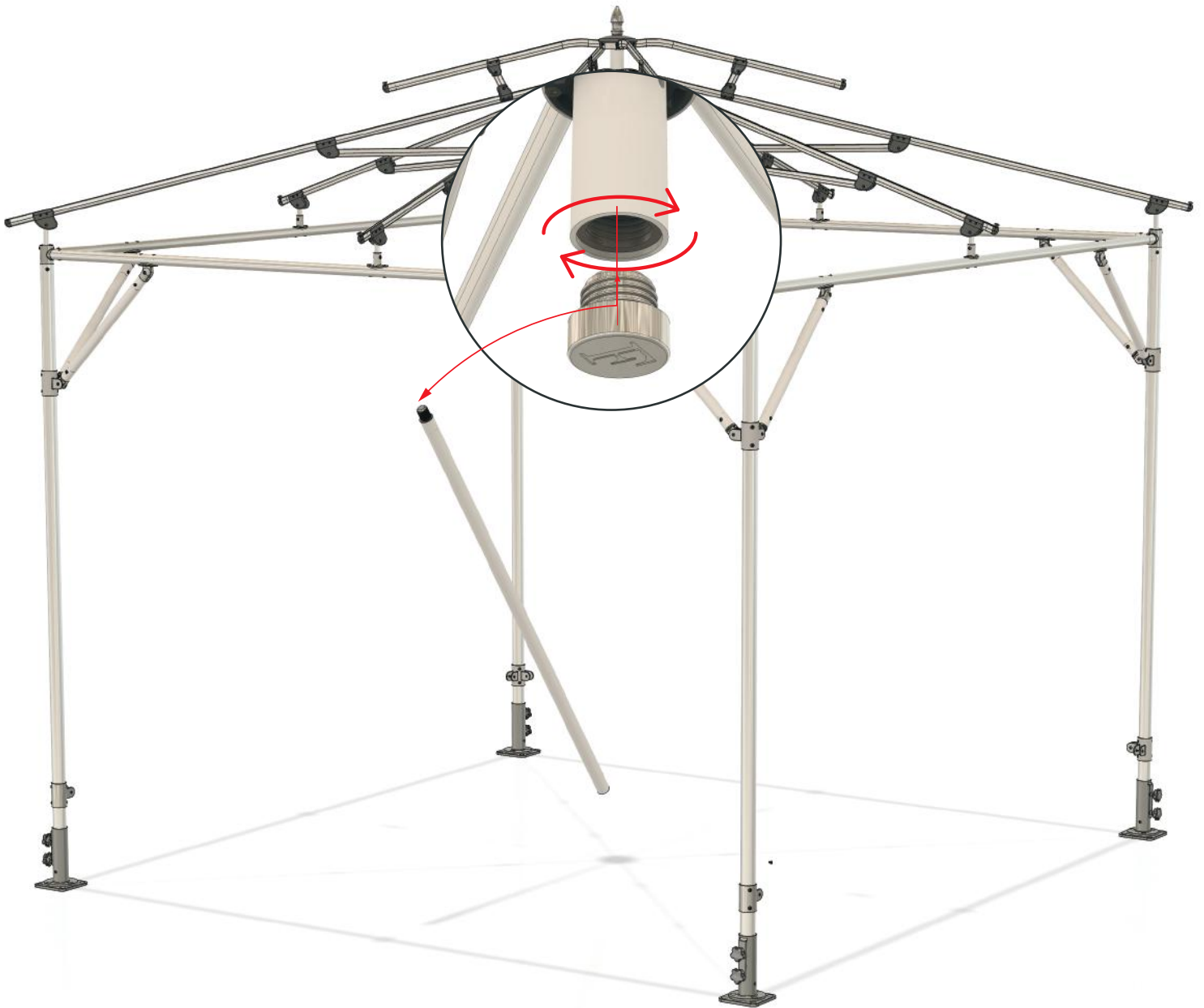

Once the canopy is docked and secured at all eight points,
Remove the center mast and install the finishing cap.

RESIDENTIAL WARRANTIES

As a condition of doing business with Frankford Umbrellas, all persons involved in the commercial purchase, sale, or resale of Frankford products shall be bound by the following terms and conditions.

DISTRIBUTION - Frankford reserves the right to respond to geographic and individual market and competitive situations by applying different policies to its various Dealers. Frankford also reserves the right to rescind or modify, in its sole and absolute discretion, any existing or future sales program or policy, or credit terms (if any) extended to a Dealer. In addition, Frankford may terminate any authorized Dealer, for any reason or no reason, in its sole and absolute discretion and without notice.

ERRORS - There may be errors in the prices, descriptions, or images of certain merchandise in our catalog or sales material. Frankford reserves the right to restrict orders of those items.

LIABILITY - In no event will Frankford be liable to the Dealer for any lost profits, lost savings, or any consequential, incidental, or special damages arising out of or in connection with the parties' relationship, even if Frankford has been put on notice of the possibility of such damages. Without limitation to the foregoing, under no circumstances will Frankford be liable to the Dealer for punitive damages.

Frankford reserves the right to alter or modify designs, product styles, or product specifications and discontinue frames and fabrics to the entire range of manufactured and distributed products without prior notice.

WIND DAMAGE - Wind ratings do not form part of, nor fall under, any of Frankford Umbrellas' warranties. Wind ratings are intended as a guide to the relative strength of the umbrellas only and tested at their optimal positions. Wind can be extremely variable, depending on the surroundings, elevation, gusts, etc.

Frankford will not be held responsible for damage to your umbrella, furniture, or property.

10-YEAR FABRIC - Frankford offers 9 oz. marine-grade solution-dyed acrylic fabric from several mills, including Sunbrella®, Outdura®, and RECASENS. All marine-grade acrylic fabrics we use carry a warranty of 10 years from the original date of purchase. All upholstery-grade fabrics we use carry a warranty of 5 years from the original date of purchase. The warranty protects against the significant loss of strength and color in normal atmospheric conditions. The product must be properly installed, maintained, and under normal use and environment. This warranty does not cover damage caused by contact with foreign objects, abuse, negligence, vandalism, burns of any kind, improper cleaning techniques, normal wear, perforations, weather soiling, environmental pollution stains, natural disasters, rot, mildew, or acts of nature.

Damage caused by the storage method or location used by clients is not covered.

To ensure our products' longevity, we recommend closing your umbrella and securing it with a tie band in high winds. In addition, be sure the fabric is pulled away from the ribs as outlined below. High winds will cause the umbrella fabric to rub together, causing friction, which can result in premature thinning of the fabric, discoloration, and possible pinholes over extended use. We strongly suggest the use of a protective cover or safely storing the umbrella until the winds and harsh weather subside. Damage of this nature is not covered under warranty.

The warranty, if applicable, does not cover labor, or the installation supplied by the dealer or reseller. The replacement fabric canopy is covered for the time remaining in the original warranty and does not activate a new 10-year or 5-year warranty.

Frankford Umbrellas' warranties do not cover damage to any umbrellas or umbrella bases related to extreme weather, abuse, misuse, or any damage that occurs as a result of contact with the ground or any other foreign object due to sudden and severe weather events or other extreme acts of nature.

Frankford Umbrellas' warranties are only applicable to products that are properly secured to Frankford bases or anchoring systems equal to or greater than recommended by Frankford. Failure to properly secure Frankford Umbrellas to Frankford bases equal to or greater than recommended will void all warranties. If warrantable damage occurs, Frankford will refinish, replace, or repair any item in this category at its own discretion.

5-YEAR FRAME - Frankford warrants the **MARELLA** for a period of 5 years from the original date of purchase. This warranty includes manufacturer defects to the notch, runner, center pole, and skeleton structure. This warranty does not include damages sustained to Marella if operated or installed improperly.

3-YEAR POWDER COAT/FINISH - Frankford warrants all powder coat finishes on aluminum masts on the **MARELLA** for a period of 3 years from the original date of purchase. This warranty includes chipping, peeling, flaking, bubbling, and fading of the powder coat finish on the aluminum masts only.

Galvanized steel will show unavoidable imperfections due to the finishing process and therefore, must be accepted in the condition in which it is received.

COMMERCIAL WARRANTIES

As a condition of doing business with Frankford Umbrellas, all persons involved in the commercial purchase, sale, or resale of Frankford products shall be bound by the following terms and conditions.

DISTRIBUTION - Frankford reserves the right to respond to geographic and individual market and competitive situations by applying different policies to its various Dealers. Frankford also reserves the right to rescind or modify, in its sole and absolute discretion, any existing or future sales program or policy, or credit terms (if any) extended to a Dealer. In addition, Frankford may terminate any authorized Dealer, for any reason or no reason, in its sole and absolute discretion and without notice.

ERRORS - There may be errors in the prices, descriptions, or images of certain merchandise in our catalog or sales material. Frankford reserves the right to restrict orders of those items.

LIABILITY - In no event will Frankford be liable to the Dealer for any lost profits, lost savings, or any consequential, incidental, or special damages arising out of or in connection with the parties' relationship, even if Frankford has been put on notice of the possibility of such damages. Without limitation to the foregoing, under no circumstances will Frankford be liable to the Dealer for punitive damages.

Frankford reserves the right to alter or modify designs, product styles, or product specifications and discontinue frames and fabrics to the entire range of manufactured and distributed products without prior notice.

WIND DAMAGE - Wind ratings do not form part of, nor fall under, any of Frankford Umbrellas' warranties. Wind ratings are intended as a guide to the relative strength of the umbrellas only and tested at their optimal positions. Wind can be extremely variable, depending on the surroundings, elevation, gusts, etc.

Frankford will not be held responsible for damage to your umbrella, furniture, or property.

7-YEAR FABRIC - Frankford offers 9 oz. marine-grade solution-dyed acrylic fabric from several mills, including Sunbrella®, Outdura®, and RECASENS. All marine-grade acrylic fabrics we use carry a warranty of 7 years from the original date of purchase. All upholstery-grade fabrics we use carry a warranty of 5 years from the original date of purchase. The warranty protects against the significant loss of strength and color in normal atmospheric conditions. The product must be properly installed, maintained, and under normal use and environment. This warranty does not cover damage caused by contact with foreign objects, abuse, negligence, vandalism, burns of any kind, improper cleaning techniques, normal wear, perforations, weather soiling, environmental pollution stains, natural disasters, rot, mildew, or acts of nature.

Damage caused by the storage method or location used by clients is not covered.

To ensure our products' longevity, we recommend closing your umbrella and securing it with a tie band in high winds. In addition, be sure the fabric is pulled away from the ribs as outlined below. High winds will cause the umbrella fabric to rub together, causing friction, which can result in premature thinning of the fabric, discoloration, and possible pinholes over extended use. We strongly suggest the use of a protective cover or safely storing the umbrella until the winds and harsh weather subside. Damage of this nature is not covered under warranty.

The warranty, if applicable, does not cover labor, or the installation supplied by the dealer or reseller. The replacement fabric canopy is covered for the time remaining in the original warranty and does not activate a new 10-year or 5-year warranty.

Frankford Umbrellas' warranties do not cover damage to any umbrellas or umbrella bases related to extreme weather, abuse, misuse, or any damage that occurs as a result of contact with the ground or any other foreign object due to sudden and severe weather events or other extreme acts of nature.

Frankford Umbrellas' warranties are only applicable to products that are properly secured to Frankford bases or anchoring systems equal to or greater than recommended by Frankford. Failure to properly secure Frankford Umbrellas to Frankford bases equal to or greater than recommended will void all warranties. If warrantable damage occurs, Frankford will refinish, replace, or repair any item in this category at its own discretion.

3-YEAR FRAME - Frankford warrants the **MARELLA** for a period of 3 years from the original date of purchase. This warranty includes manufacturer defects to the notch, runner, center pole, and skeleton structure. This warranty does not include damages sustained to Marella if operated or installed improperly.

3-YEAR POWDER COAT/FINISH - Frankford warrants all powder coat finishes on aluminum masts on the **MARELLA** for a period of 3 years from the original date of purchase. This warranty includes chipping, peeling, flaking, bubbling, and fading of the powder coat finish on the aluminum masts only.

Galvanized steel will show unavoidable imperfections due to the finishing process and therefore, must be accepted in the condition in which it is received.

CARE AND MAINTENANCE

FABRIC CARE - Recacril® 9 oz. marine-grade acrylic fabric is treated with the Infinity Process, a highly technological finish providing Recacril® with long-lasting protection against mold and mildew, excellent water and oil repellency, and protection from the sun. However, the accumulation of dust, pollution particles, foreign organic materials, and general dirt can damage this protection, shortening the life of the Recacril®.

The most effective method for maintaining Recacril® is to clean the canvas once a month with water, using a low-pressure hose. It is very important that after cleaning with water, the canvas be allowed to completely dry before rolling or storing your umbrella. If for any reason you must roll and/or store a wet umbrella, it must be unrolled and opened as soon as possible to dry. In times of continuous rain, it is advisable to keep the umbrella rolled and stored.

If periodic washing with water is done, in most environments, you should only need to do a more thorough cleaning every 2-3 years.

Recacril® is highly resistant to the growth of fungus, mold, and mildew. However, these can grow on embedded dirt. To clean these stains, follow these more intensive cleaning procedures.

FABRIC CRAZING/MARBLING - Crazing is an inherent characteristic of all solution-dyed acrylic fabrics and is caused by folding or creasing of the fabric during production or installation.

- Crazing lines appear as white lines on dark-colored fabrics when frontlit, and dark lines on light-colored fabrics when backlit. The primary contributors to crazing are the resins added in the final stages of manufacturing. These resins add stiffness so the fabric lies flat during sewing, which is critical for the manufacturing process.
- These resins can be viewed as an industrial fabric starch with a specific end purpose. Crazing does not affect the performance or characteristics of RECASENS, Sunbrella®, Outdura®, or other acrylic fabrics. The fabric remains water repellent as well as stain and mildew resistant, and the lines will diminish over time with exposure to the elements.

CASUAL CARE/CLEANING

- Brush off dust and dirt with a soft brush. NEVER brush with stiff brushes since this can damage the fabric finish.
- Spray the umbrella with clean water. If a hose is used, avoid high pressure.
- Prepare a solution of solvent-free soap in warm water (no more than 100°F) and apply it to the fabric and stitching.
- Scrub with a soft brush, allowing the solution to penetrate the fabric.
- Rinse with water to remove all traces of soap.
- Let air dry and do not close the umbrella until canvas is completely dry.

INTENSIVE CARE/CLEANING

- Brush off dust and dirt with a soft brush. NEVER brush with stiff brushes as this can damage the fabric finish.
- Prepare a solution with 10% household bleach, 20% solvent-free neutral detergent (free & clear detergents), and 70% water.
- Apply the solution to the fabric, allowing it to remain between 15 and 20 minutes maximum.
- Rinse with clean water several times. Any bleach residues remaining on the canvas, combined with the sun, could damage the fabric and stitching.
- Let air dry and do not close the umbrella until canvas is completely dry.
- Repeat the process if necessary.

Never leave bases standing in water. To keep your bases looking their best, you may wish to store them when not in use for an extended period of time.

Finishes will vary slightly depending on the final process and raw materials on which they are applied.

VISUAL RUST - If you notice rust stains, rinse the steel product with warm water and a mild detergent to determine its origin. Once the damaged area has been discovered, scrub off the visible rust using warm water, white vinegar, and a stainless steel wire brush (steel wire brushes will leave further iron deposits on the surface).

Once rust (orange oxidation) is visibly gone, apply a thin coat of Rust-Oleum® Stops Rust® Rust Inhibitor Spray to the affected area. Then apply the closest-matching Rust-Oleum® paint available at your local hardware store.

Rusty water stains may appear from rusting ferrous metal deposits on the surface, not the actual product. The most common place this would occur is from the umbrella stem/threads. Remove the stem and clean with warm, fresh water; white vinegar; and a soft sponge or brush. Dry off with a towel, apply WD-40 Specialist Long-Term Corrosion Inhibitor to the threads of the umbrella stem and female receiving cup of the stem.

CLEANING ABS PLASTICS - Frankford uses electroplating on our plastic crank boxes for Brushed Silver (**MS**) and Platinum (**SR**) finishes. This is to protect the plastic parts from corrosion. The plating process will also increase the wear resistance and strength of the product. To clean these specific finishes, follow the methods below.

TOOTHPASTE - Removes light scuffs and cloudiness.

- Spread a thin layer of opaque white (no gel) toothpaste on the surface of the chrome plating. Rub the toothpaste with a soft, clean cloth in small circular and swirling patterns (little to no force).
- Using a fresh, dry cloth or microfiber, wipe away the toothpaste, revealing a shiny, clean surface.

WHITE VINEGAR - General Cleaning.

- Pour undiluted distilled white vinegar in to a spray bottle and begin to spray the surface until saturated.
- Using a fresh, dry cloth or microfiber, wipe while simultaneously buffing away the vinegar.

