

# Stella Interior Stacking Chair

Passes ASTM F 1561 Class B standard for safe commercial outdoor use.

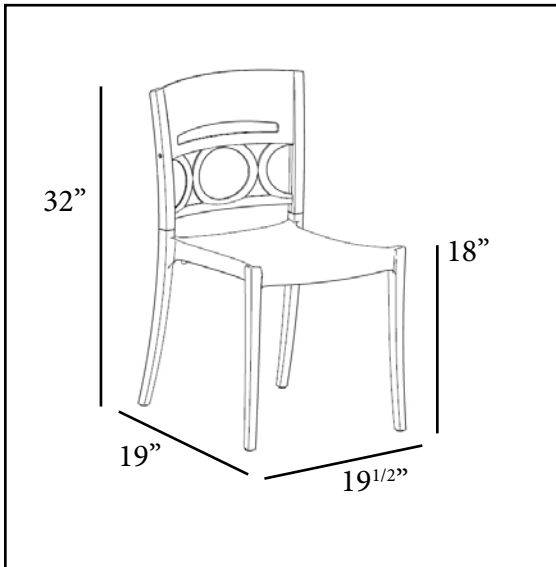

**Features & Benefits** **Warranty: 3 Yrs.**

- Contemporary polymeric material rendition of a traditional cast design of the antique world.
- Low backrest with a wide ergonomic seat.
- Transparent color hues to brighten the outdoor design scheme.
- Stacks for easy storage.
- Easy to handle and move around patios and terraces.
- Can easily be cleaned with soap and water.
- Rated to 300 lbs. for safe use in commercial environments.

<b>Product Specifications</b>						
Product Description	Reference Number	Color	UPC Code 014306	Weight Each (lbs.)	Master Pack	Master Pack Volume (cu. ft.)
Stella Outdoor Stacking Chair	XA627241	Turquoise/White	911038	9.10	16	36.80
	US627241	Turquoise/White	911038	10.00	4	21.52
	XA627208	Smoke/White	911052	9.10	16	36.80
	US627208	Smoke/White	911052	10.00	4	21.52
	XA627237	Celery Green/White	911021	9.10	16	36.80
	US627237	Celery Green/White	911021	10.00	4	21.52
	XA627206	Clear/White	911014	9.10	16	36.80
	US627206	Clear/White	911014	10.00	4	21.52
	XA627207	Red/White	911045	9.10	16	36.80
	US627207	Red/White	911045	10.00	4	21.52